

Constitutional structures

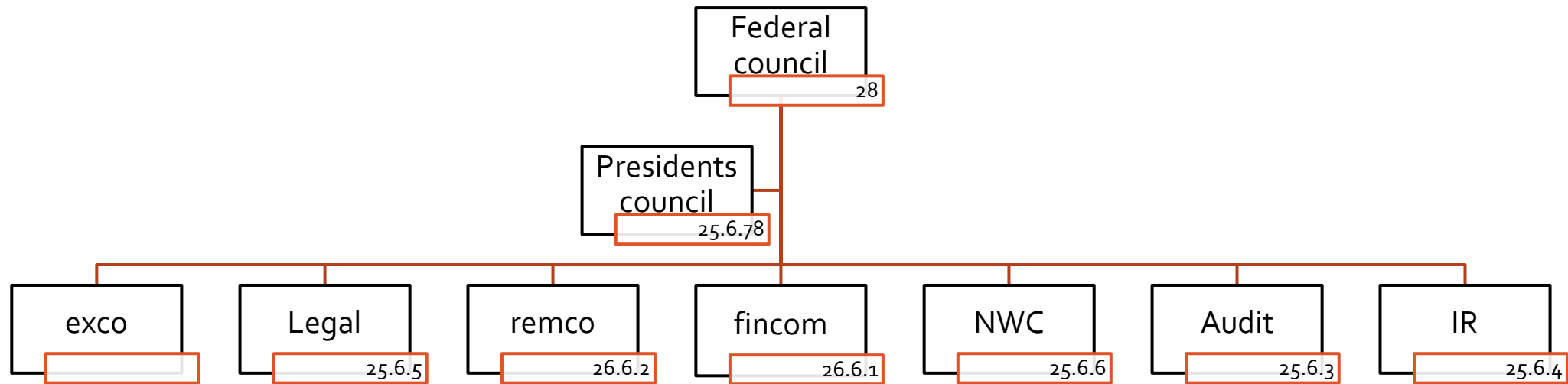

Functions of the committees

- Constitutional van guard of the organization
- Implement the objectives as stated in the constitution clause 3 page 5
- Committees functions labeled in the constitution

Functions of exco members as per constitution

President

Deputy
Legal
Investments

Vice
Security
Events /
publications

Buthelezi
Research
/training/development

SG

HR

maintenance

Nwc/parliament

Admin/marketing/econo
micws

remco

Logistcs/Disciplinary/chi
efwhip

TG

audit

Fund raising

Finance/budget

organogram

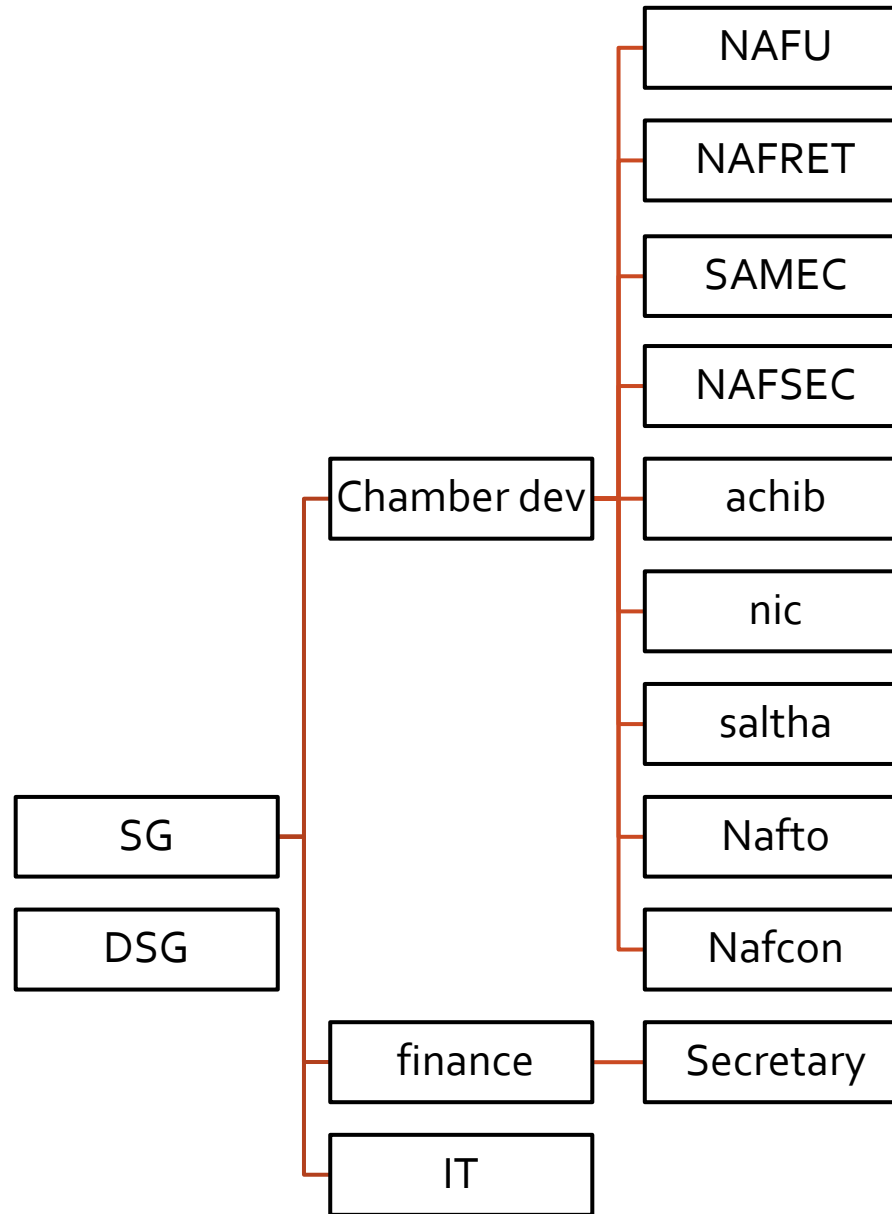

Functions of the chamber development managers

- Coordinate membership recruitment for NAFCOOC and the sectors
- Liase between the Nafcoc head office and the structures secret /presidents
- Provide weekly reports to the D SG at NAFCOOC
- Attend weekly meetings organized by the Administration
- Collect membership and file the necessary documents
- Visit members at provincial and regional levels
- Provide business information, advice ,counselling and training to members
- Establish branches and study groups to advocate on business relations ,profitability and projects establishment
- Relationship organizing with relevant stake holders
- To keep membership register and populate the database.
- Perform other duties that are chamber development related
- To improve productivity within the organization

Functions of the finance and admin office

- Administer finances of the organization
- Reports to the treasurer
- Fundraise for the organization
- Control budgets and approve spending of the organization
- Audit the books of the organization
- Submit management and financial accounts to the treasurer
- Debtors and creditors control and management
- Staff salaries and contracts relations management